

Fellowes

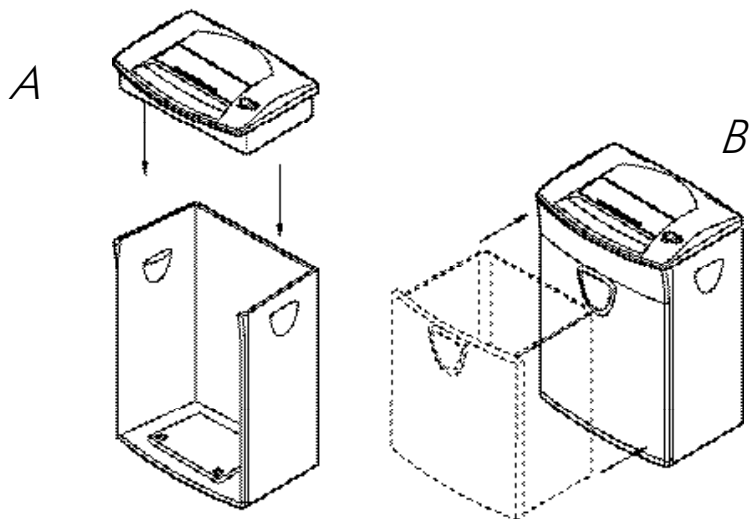

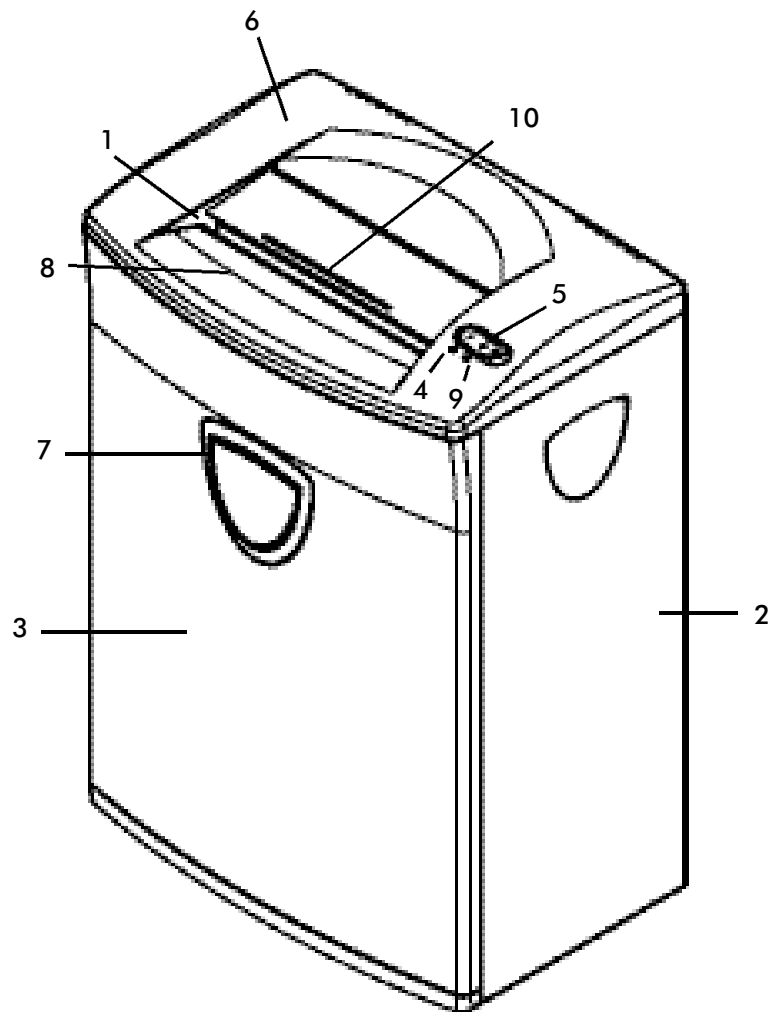

Fellowes

Dear Customer,

Thank you for buying a Fellowes Personal Shredder. We have made many improvements in our personal shredder since its introduction in 1990 as the first of its kind on the market. We are confident that it offers you the greatest value for your money in its product category today. We hope it meets – or even exceeds – your expectations.

To ensure years of safe, efficient use, please read these few pages about your new shredder. If this manual doesn't answer all your questions or if you wish to comment on this product, we welcome your call or letter.

Sincerely,

James Fellowes
Chairman & CEO

Contents

Product Profile	3
Important Safety Instructions	3
Set-Up	4
Operation	4
Maintenance	5
Troubleshooting	5
Limited Warranty	6

Product Profile

This product is built to shred **paper, staples, small paper clips, credit cards, CDs and DVDs**. It is *not* built to take large paper clips, continuous forms, adhesive labels, transparencies, newspaper, cardboard or any plastic other than credit cards. Using it for these purposes is likely to cause irreparable damage.



	Strip-cut OD1500	Confetti Cut OD1500C
Sheet capacity*	15 sheets	10 sheets
Paper shred size	7/32" (5.8 mm)	5/32" x 1-1/2" (3.9 x 38 mm)
CD/DVD capacity	1	1
Maximum paper width	9" (229 mm)	
Recommended daily capacity	50-100 shredding passes	
Maximum running time	20 minutes	
Automatic cool-down period	30 minutes	
Voltage	120 V / 60 Hz / 6.0 A	

*Based on 20 lb., 8-1/2" x 11" (70gsm, A4) paper with shredder operating at rated voltage; heavier paper, high humidity, or other than rated voltage may reduce sheet capacity.



IMPORTANT SAFETY INSTRUCTIONS READ ALL INSTRUCTIONS BEFORE USING

While setting up shredder

- Check shredder for damage or defects; some paper particles in the basket are normal due to product testing and does not indicate a defect.
- If the cord is damaged do not replace cord or use the machine. Return machine for a replacement.
- Avoid touching exposed blades on underside of OD1500C confetti-cut shredder head.
- Plug power cord in an outlet that can easily be reached.
- Do not place shredder near or over a heat or water source.

While operating shredder

- Keep hands and hanging objects (jewelry, ties, loose clothing, long hair, etc.) away from paper entry.
- Keep children and pets away from the shredder.



When not in use

- Always turn off and unplug shredder
- Unplug before emptying basket
- Do not open shredder head: Danger of electric shock.



NOTE: Do not use flammable synthetic oil, petroleum-based products or aerosols of any kind on or near product at any time.



Set-Up

This shredder will only operate when used with the supplied basket. The supplied basket has a built-in safety feature which prevents the shredder from operating if used with any other basket or if improperly assembled.

- Position shredder head (6) over cabinet (2). Place shredder head on top of cabinet as shown in Figure A.
- Firmly push down on four corners of shredder head to “lock” shredder head into position.
- Push basket (3) into shredder cabinet as shown in Figure B. Basket must be pushed firmly, so edges of basket/cabinet are aligned properly.

NOTE: To disassemble, pull out basket, hold cabinet down by placing foot on bottom shelf, and firmly pull up on shredder head.

Operation

For convenience, your shredder is equipped with an **automatic-start sensor (8)**. This means that when the control switch (5) is in the automatic [I] position, the shredder will start running when paper is fed into it. The shredder stops a few seconds after the paper has passed through. Because the sensor cannot tell the difference between paper and other objects, this feature can be a hazard, especially to children and pets. To avoid accidents, turn off the shredder as soon as you are finished. Unplug shredder if it will not be used for an extended period.

To shred

- Plug in shredder with control switch (5) in off [O] position
- Press control switch to automatic [I] position; cutting cylinders will run for 1-2 seconds to signal readiness and green light (4) will turn on.

PAPER

- Feed paper straight into entry (1), until the shredder automatically begins shredding; see *Product Profile* for limits on paper width, shreddable items, sheet capacity, etc.
- Shred for no more than 20 minutes; shredding longer will cause shredder to turn itself off for 30 minutes to cool down.
- Press control switch to off [O] position after cutting has stopped. With confetti-cut shredder, cutting continues for several seconds after paper has gone through in order to clear shredded paper from cutting cylinders.

CDs and DVDs

- Hold CD or DVD at the edge and feed one at a time, straight into CD entry (10), releasing when shredding begins. Shredder will stop when CD has passed through entry. CDs will be shredded into small particles.

CAUTION: Do not hold CD or DVD with finger through the center ring while feeding into shredder.

In case of a **paper jam**, which may occur if the sheet capacity is exceeded or if paper is not put in straight, turn off and empty the basket if full. Then:

- 1) Press and hold control switch in reverse [R] position and attempt to back paper out of shredder.
- 2) If shredder jams in reverse mode, press control switch to automatic [I] position and attempt to continue shredding operation.
- 3) If shredder jams again, alternate control switch slowly between reverse [R] and automatic [I] positions to attempt to move jammed paper completely through shredder.

If you are unable to clear the jam using this method, turn off and unplug the shredder; remove wastebasket from the cabinet and carefully remove any paper extending below the cutting cylinders; insert wastebasket and repeat jam clearing procedure.

Maintenance

Regular emptying of the basket is important to ensure the smooth operation of the cutting cylinders. If you can see paper in the basket window (7), turn off the shredder, pull out basket and empty basket contents.

Regular oiling of the confetti-cut model (OD1500C) is also necessary to ensure proper performance. If you are running the shredder at or near capacity, we recommend oiling it monthly. Using Fellowes Powershred Lubricant #35250 or other non-aerosol vegetable-based oil in a long-nozzle container:



- Apply oil over full width of paper entry (1) with shredder in off [O] position.
- Press control switch to automatic [I] position which will cause shredder to run for about 2 seconds.
- Press and hold control switch in reverse [R] position for 3–5 seconds.
- Repeat above automatic [I] and reverse [R] sequence three times.

REMINDER: Do not use flammable synthetic oil, petroleum-based products or aerosol lubricants of any kind in or near the shredder at any time.



Troubleshooting

If you have a problem with your shredder, check the symptoms and remedies below. If you cannot solve the problem this way, contact Fellowes Customer Service. **Do not open shredder head** to attempt repair: It could expose you to serious electric shock and will void your warranty.

Symptom	Remedy
Shredder does not start or stops while shredding.	<ul style="list-style-type: none"> • Make sure shredder is plugged in and switch is in automatic [I] position. • If paper appears to be jammed, follow instructions under <i>Operation</i>. • Check basket position; basket must be pushed all the way in the cabinet. Follow instructions under <i>Set-Up</i>.
Red display light (9) turns on and shredder will not operate.	<ul style="list-style-type: none"> • Wait 30 minutes for shredder to cool down before trying again. • If paper appears to be jammed, follow instructions under <i>Operation</i>.
Shredder squeaks, grinds or runs below capacity.	<ul style="list-style-type: none"> • Check basket position; basket must be pushed all the way into the cabinet. Follow instructions under <i>Set-Up</i>. • Oil cutting cylinders (OD1500C only). Follow instructions under <i>Maintenance</i>.
Shredder continues to run for a few seconds after paper has cleared the cutting cylinders.	<ul style="list-style-type: none"> • Check window. If paper is visible, empty basket. Follow instructions under <i>Maintenance</i>. No action required. This is a self-cleaning function.

Customer Service

Fellowes offers a **toll-free help line** for customers living in the United States, Canada, Mexico and Australia. If you live outside these regions or are otherwise unable to use our help line, please call the Fellowes location nearest you, send a letter or email, or contact your local dealer. All of our customer service phone numbers and other points of contact are listed on the back of this manual.

Limited Warranty

Fellowes, Inc. warrants the cutting cylinders of the machine to be free from defects in material and workmanship for **7 years** from the date of purchase by the original consumer. Fellowes warrants all other parts of the machine to be free of defects in material and workmanship for **1 year** from the date of purchase by the original consumer. If any part is found to be defective during the warranty period, your sole and exclusive remedy will be repair or replacement, at Fellowes' option and expense, of the defective part.

This warranty does not apply in cases of abuse, mishandling or unauthorised repair. ANY IMPLIED WARRANTY, INCLUDING THAT OF MERCHANTABILITY OR FITNESS FOR A PARTICULAR PURPOSE, IS HEREBY LIMITED IN DURATION TO THE APPROPRIATE WARRANTY PERIOD SET FORTH ABOVE. IN NO EVENT SHALL FELLOWES BE LIABLE FOR ANY CONSEQUENTIAL OR INCIDENTAL DAMAGES ATTRIBUTABLE TO THIS PRODUCT. This warranty gives you specific legal rights. You may have other legal rights that vary. The duration, terms and conditions of this warranty are valid worldwide, except where different limitations, restrictions or conditions may be required by local law.

For more details or to obtain service under this warranty, please contact us (see back cover) or your dealer.

Help Line

Australia	+ 1-800-33-11-77
Canada	+ 1-800-665-4339
México	+ 1-800-234-1185
United States	+ 1-800-955-0959

Fellowes

Australia	+ 61-3-8336-9700
Benelux	+ 31-(0)-347-377988
Canada	+ 1-905-475-6320
Deutschland	+ 49-(0)-5131-49770
France	+ 33-(0)-1-30-06-86-80
Italia	+ 39-(0)-71-730041
Japan	+ 81-(0)-3-5496-2401
Korea	+ 82-(0)-2-3462-2884
Malaysia	+ 60-(0)-35122-1231
Polska	+ 48-(0)-22-837-7356
Singapore	+ 65-6221-3811
United Kingdom	+ 44-(0)-1302-836836
United States	1-630-893-1600

www.fellowes.com

Fellowes

1789 Marwood Avenue

Itasca, Illinois 60143-1085

630-963-1600

<http://www.fellowes.com>

Australia

Benelux

Canada

France

Germany

Italy

Japan

Korea

Poland

Singapore

United Kingdom